



### Nominal data

Type	8412 NGMLV	
Nominal voltage	VDC	12
Nominal voltage range	VDC	8 .. 14
Speed (rpm)	min <sup>-1</sup>	2050
Power consumption	W	1.5
Min. ambient temperature	°C	-20
Max. ambient temperature	°C	65
Air flow	m <sup>3</sup> /h	45
Sound power level	B	3.9
Sound pressure level	dB(A)	19

ml = Max. load · me = Max. efficiency · fa = Free air · cs = Customer specification · ce = Customer equipment  
Subject to change

### Technical description

<b>Housing material</b>	Glass-fiber reinforced PBT plastic
<b>Impeller material</b>	Glass-fiber reinforced PA plastic
<b>Weight</b>	0.095 kg
<b>Dimensions</b>	80 x 80 x 25 mm
<b>Airflow direction</b>	Exhaust over struts
<b>Direction of rotation</b>	Counterclockwise, viewed toward rotor
<b>Storage</b>	Sintec sleeve bearing
<b>Service life L10 at 40 °C</b>	80000 h
<b>Service life L10 at maximum temperature</b>	45000 h
<b>Cable</b>	Leads AWG 24, TR 64, stripped and tin-plated.
<b>Motor protection</b>	Protection against reverse polarity and blocked rotor.
<b>Locked-rotor protection</b>	Locked-rotor and overload protection
<b>Approval</b>	VDE, CSA, UL, CE
<b>Option</b>	Possible custom designs: Speed signal Go / No-go alarm External temperature sensor Internal temperature sensor Moisture protection

## Product drawing

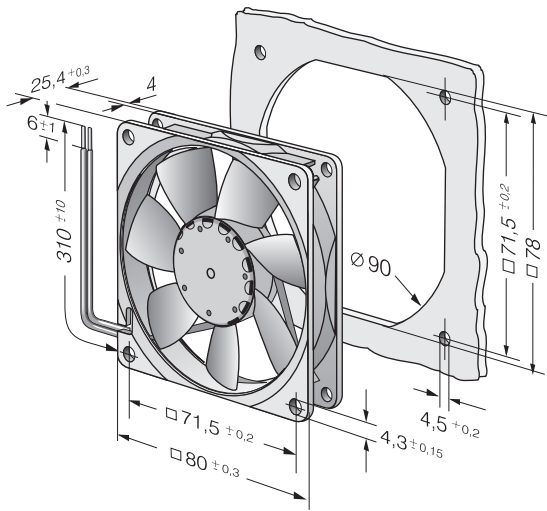

Connection diagram

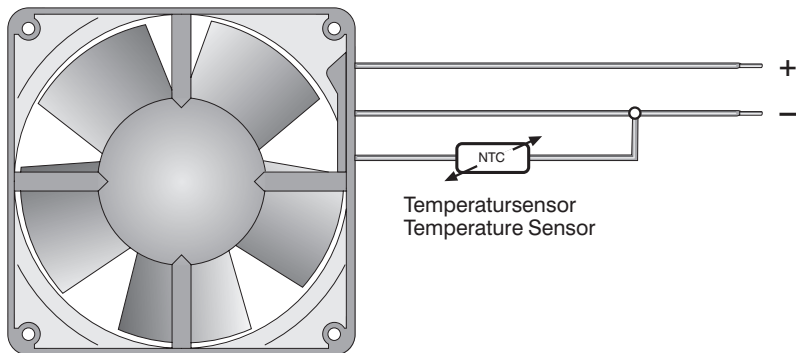

## Curves: Air performance

